

JUNG PUMPEN

U3 K - U3 KS - U3 K SPEZIAL - U3 KS SPEZIAL

U5 K - U5 KS

U6 KE - U6 KES - U6 KD - U6 KDS

DE Original-Betriebsanleitung

EN Instruction Manual

FR Instructions de service

NL Gebruikshandleiding

IT Istruzioni per l'uso

PL Instrukcja eksploatacji

CZ Návod pro provoz

SK Návod na prevádzku

HU Üzemeltetési útmutató

RO Manual de utilizare



You have purchased a product made by JUNG PUMPEN and with it, therefore, also excellent quality and service. Secure this service by carrying out the installation works in accordance with the instructions, so that our product can perform its task to your complete satisfaction. Please remember that damage caused by incorrect installation or handling will adversely affect the guarantee.

Therefore please adhere to the instructions in this manual!

As with all electrical devices, this product can also fail to operate due to an interruption in the electricity supply or due to a technical defect. If this could result in damage, a mains-independent alarm system must be installed. Depending on the application, you may also wish to install an emergency power generator, or a second system as a back-up.

SAFETY INSTRUCTIONS

This instruction manual contains essential information that must be observed during installation, operation and servicing. It is therefore important that the installer and the responsible technician/operator read this instruction manual before the equipment is installed and put into operation. The manual must always be available at the location where the pump or the plant is installed.

Failure to observe the safety instructions can lead to the loss of all indemnity.

In this instruction manual, safety information is distinctly labelled with particular symbols. Disregarding this information can be dangerous.



General danger to people



Warning of electrical voltage

ATTENTION!

Danger to equipment and operation

Qualification and training of personnel

All personnel involved with the operation, servicing, inspection and installation of the equipment must be suitably qualified for this work and must have studied the instruction manual in depth to ensure that they are sufficiently conversant with its contents. The supervision, competence and areas of responsibility of the personnel must be precisely regulated by the operator. If the personnel do not have the necessary skills, they must be instructed and trained accordingly.

Safety-conscious working

The safety instructions in this instruction manual, the existing national regulations regarding accident prevention, and any internal working, operating and safety regulations must be adhered to.

Safety instructions for the operator/user

All legal regulations, local directives and safety regulations must be adhered to.

The possibility of danger due to electrical energy must be prevented.

Leakages of dangerous (e.g. explosive, toxic, hot) substances must be discharged such that no danger to people or the environment occurs. Legal regulations must be observed.

Safety instructions for installation, inspection and maintenance works

As a basic principle, works may only be carried out to the equipment when it is shut down. Pumps or plant that convey harmful substances must be decontaminated.

All safety and protection components must be re-fitted and/or made operational immediately after the works have been completed. Their effectiveness must be checked before restarting, taking into account the current regulations and stipulations.

Unauthorised modifications, manufacture of spare parts

The equipment may only be modified or altered in agreement with the manufacturer. The use of original spare parts and accessories approved by the manufacturer is important for safety reasons. The use of other parts can result in liability for consequential damage being rescinded.

Unauthorised operating methods

The operational safety of the supplied equipment is only guaranteed if the equipment is used for its intended purpose. The limiting values given in the "Technical Data" section may not be exceeded under any circumstances.

Instructions regarding accident prevention

Before commencing servicing or maintenance works, cordon off the working area and check that the lifting gear is in perfect condition.

Never work alone. Always wear a hard hat, safety glasses and safety shoes and, if necessary, a suitable safety belt.

Before carrying out welding works or using electrical devices, check to ensure there is no danger of explosion.

People working in wastewater systems must be vaccinated against the pathogens that may be found there. For the sake of your health, be sure to pay meticulous attention to cleanliness wherever you are working.

Make sure that there are no toxic gases in the working area.

Observe the relevant occupational health and safety regulations and keep first aid materials available.

In some cases, the pump and the pumping medium may be hot and could cause burns.

For installations in areas subject to explosion hazards, special regulations apply!

This appliance can be used by children aged 8 years or over and by persons with limited physical, sensory or intellectual capabilities, or with limited experience and knowledge, provided that they are supervised or have been instructed in the safe use of the appliance and are aware of the dangers involved. Children must not be allowed to play with the appliance. Cleaning and user maintenance must not be carried out by children unless they are supervised.



The pump must only be connected to sockets that have been installed properly in accordance with the regulations and are protected with at least 10 A (slow) and FI-safety switches (30mA).



Check the rubber hose for mechanical or chemical damage. A damaged or kinked hose must be replaced.



The pump must never be used when a person is in the water.

APPLICATION

Submersible pumps from the U3, U5 and U6 series are suitable for pumping domestic waste water without stones. This includes also water from household dishwashers and household washing machines.

The U3 K spezial can also pump aqueous solutions with up to 10% salt content and condensate from gas condensing boilers.

The U6 can also pump ground water, drainage silage liquor and liquid manure.

When using the pumps, the relevant national laws, regulations and stipulations must be adhered to, for example:

- Domestic contaminated and waste water (e.g. EN 12056 in Europe)
- Installation of low voltage systems (e.g., VDE 0100 in Germany)

For non-standard utilization conditions, further regulations must be observed (e.g. VDE 0100 in Germany, part 701: bathrooms and shower rooms; part 702: swimming pools and fountains and part 737: outdoor use).

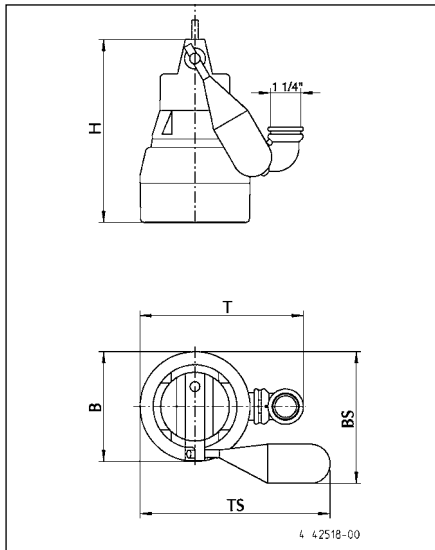

Temperatures

The pumped medium must have a temperature of max 35°C.

The submersible pump is frost-resistant down to -20°C when stored in dry conditions. When installed, however, it must not be allowed to freeze in the water.

Transport



The pump must always be lifted by the handle and never by the power supply cable! The pump should only be lowered into deeper chambers or pits using a rope or chain.

Dimensions [mm]

	H	B	T	BS	TS
U3 K	255	160	225	195	280
U5 K	280	170	250	205	290
U6 K	335	175	255	210	295

Pumps with special float assembly, (JP44795)

	H	BS	TS
U3 KS	225	270	220

Pumps with special float assembly, (JP44207)

	H	BS	TS
U5 KS	280	245	285
U6 KS	335	250	290

Switching points On - Off for built-in switching

	Normal		Special	
	●	○	●	○
U3 KS	215	110	105	45
U5 KS	240	135	-	-
U6 KS	270	170	-	-

ELECTRICAL CONNECTION



Only qualified electricians may carry out electrical works to the pump or the controls.



Before carrying out any works: disconnect the pump and the controls from the mains and take steps to ensure that no one else can reconnect them to the power supply.

The relevant standards (such as EN standards), country-specific regulations (such as VDE in Germany), and the regulations of the local power supply companies must be observed.

ATTENTION! Never put the mains plug or a free lead end in water! If water gets into the plug, this can cause malfunctions and damage. Observe the operating voltage (see the type plate)!

The pump is provided with a winding thermostat. In case of unacceptably high temperatures it switches off the pump to protect it against possible damage. Unacceptably high temperatures may result e.g. from dry running or mechanical or electrical overload.



The pump is switched on again automatically after cooling down - risk of injury! For this reason, always disconnect the device from the mains before remedying the fault! In order to do this, unplug from the mains supply or remove the pre-fuses of the pump controls!

Alternating and three-phase current circuit diagrams

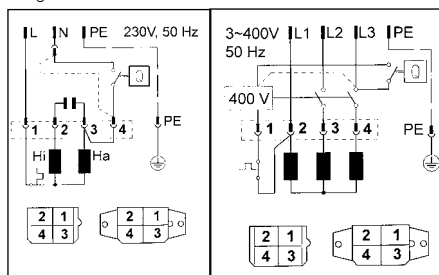

Rotational direction

Applies only for three-phase pumps. The rotational direction must be checked before installation! If the rotational direction is correct, the start-up jolt should be counter-clockwise. If the rotational direction is wrong, 2 phases of the supply cable must be swapped over, because a wrong direction of rotation results in an overload of the pump.

INSTALLATION

The pump must be installed as shown in the examples. For installations in accordance with EN 12056-4, the pressure pipe must be laid in a loop above the local backflow level and protected with a backflow prevention valve. The rubber flap supplied (U3 and U5) is for mobile operation only.

A correspondingly larger diameter pipe should be used for longer pressure pipelines to avoid pipe friction losses.

In contrast to pumps with built-in level control, the ON an OFF switching heights of pumps without built-in level control are variable by the use of a separate level controller. Our ready to connect level controls can be installed without specific electrotechnical skills.

Permanent venting may be necessary if the pump runs dry from time to time (pressure outlet surfaced). This can occur for example if the residual water in the collecting chamber evaporates or if the pump runs in "snore" mode during the test run.

To vent the pump housing the attached elbow must be drilled at the marked location to provide a 6 mm drill-hole.

ATTENTION! If the pump is malfunctioning, part of the contents of the oil reservoir could escape into the pumping medium.

Dimensions of chamber

Single installation with pump base: 40 x 40 cm
 Single installation with guide rail system: 40 x 50 cm and Duplex installation: 50 x 50 cm

Example of installation with guide rail system

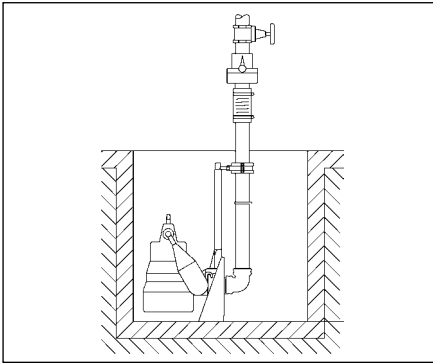

Installation

Fix the coupling base firmly to the floor of the collection chamber using wall plugs and then mount the guide rail. Next, install the pressure pipe including the necessary fittings, such as the non-return valve and shut-off valves.

Reseal the coupling catch at the pump and tighten it until it is "hand tight". Finally, fit the pump with the coupling catch onto the guide rail and lower it into place using a chain fixed to the handle.

Example of installation Duplex unit

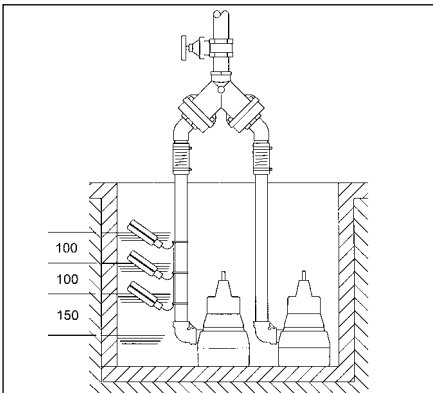

ATTENTION! The floats of the level controller and alarm system are installed so that they are freely movable but not under the inlet. Please

observe the minimum distances. The controls may only be installed in a dry and well ventilated room!

Flushing device

The pump can keep the intake section at the bottom of the chamber clear of deposits to a large extent if you carry out a small modification. This reduces the performance of the pump only insignificantly.

This modification is carried out as follows. Detach the foot strainer and carefully drill a hole into the 3 markings with the $\varnothing 5$ symbols. Deburr the drillholes. When reattaching the foot strainer, ensure that the new drill-holes are not covered by the bars of the foot strainer. The U5 and U6 ranges provide markings on the housing and the foot strainer to help you.

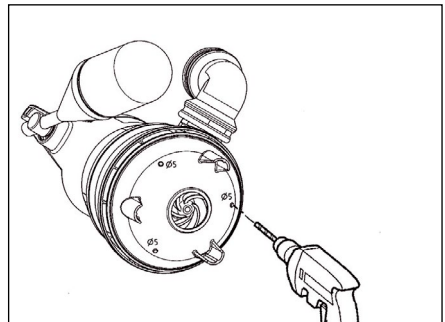

Low level pumping

Flooded areas can be pumped out leaving only few mm of residual water without the need for optional extras, U3K: 5 mm, U5K: 6 mm and U6K: 10 mm. To do so, the foot strainer must be levered off with a screwdriver. In the case of pumps with an attached control, the float switch must be locked in the ON position. It is not possible therefore in low level pumping to operate the pump in switching mode.

To make the pump operate, the drainage hose must be emptied before each pumping run and there must be a minimum water level available of, for U3K: 40 mm, for U5K: 60 mm and for U6K: 90 mm.

Mobile operation

For safety reasons, mobile operation is only allowed with a foot strainer.

If a hose is used as a pressure line, care must be taken to ensure that for every pumping operation the hose is completely empty before the pump is submersed. Any residual liquid would obstruct the ventilation of the pump housing and therefore also hinder the pumping operation. For the same reason, the pump would not operate if it was switched on before being submersed.

The pump can also be vented by providing a 6 mm drill-hole in the pump housing. This drill-hole allows the pump to be vented even if the rubber flap is used.

The enclosed rubber flap (not Flutbox) is fitted in the pressure outlet (U3) or in the attached elbow (U5). Ensure that the flap opens in the direction of flow.

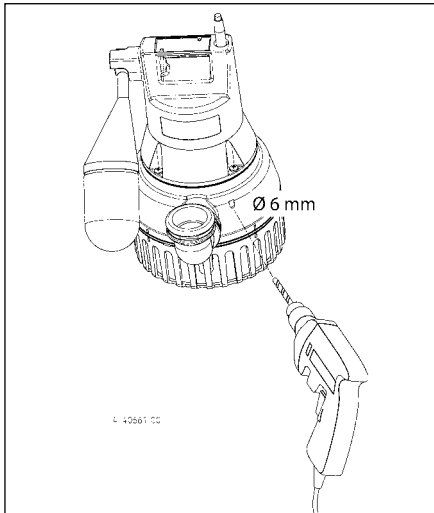

Enlarging the free passage

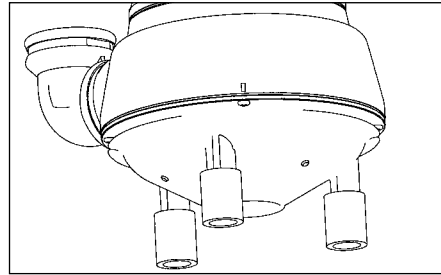

The free passage of the U5 and U6 pump ranges can be enlarged from 10 to 20 mm. This is done by levering off the foot strainer and attaching the enclosed extensions to the integrally molded pump feet. The foot strainer no longer fits under the pump.

MAINTENANCE

We recommend that you service the equipment in accordance with EN 12056-4.



Before carrying out any works: disconnect the pump and the controls from the mains and take steps to ensure that no one else can reconnect them to the power supply.



Check the rubber hose for mechanical or chemical damage. A damaged or kinked hose must be replaced.

Attention! If the water contains high levels of iron or lime, insufficient cleaning can result in irreparable damage to the seal and thus also to the pump motor in the long term.

Consequently, the pump must be cleaned at regular intervals according to the hardness of the water.

Cleaning

The foot strainer prevents coarse impurities from entering the pump. Regular cleaning of the float and the foot strainer ensures optimum performance and operation.

Cleaning of the impeller (U5 and U6)

To clean the impeller, and in the event of an obstacle or blockage, the foot strainer must be levered off. After this, take out the screws on the underside of the pump and remove the cover. The impeller can now be cleaned.



Worn impellers can have sharp edges.

If the pump performance decreases, the impeller must be checked for wear and replaced by the manufacturer if necessary.

Tightening torque M_A for A2 screw materials

for M 5 $M_A = 5 \text{ Nm}$

for Amtec 3,5 $M_A = 1 \text{ Nm}$

for Amtec 5,0 $M_A = 2 \text{ Nm}$

QUICK TIPS FOR REMEDYING FAULTS

No pump operation

- Check mains current (do not use a pin gauge)
- Fuse faulty = may be too weak (please refer to Electrical Connection)
- Mains supply cable damaged = repair to be carried out by manufacturer only

Pump runs but does not pump

- Empty the pressure pipe or hose to allow the non-return valve to open and the air to escape from the pump housing, it may be necessary to carry out a ventilation drilling

Impeller blocked

- Solids and fibrous matter have become lodged in the pump housing = clean

Decreased pumping performance

- Foot strainer obstructed = clean
- Pressure pipe obstructed = clean
- Rotor worn out = repair to be carried out by the manufacturer
- Wrong direction of rotation (for a three-phase current) = ask a qualified electrician to change 2 phases of the supply line

 0197	
JUNG PUMPEN GmbH - Industriestr. 4-6 33803 Steinhagen, Germany 13 401.11.1404	
EN 12050-2:2001 Lifting plant for faecal-free wastewater DN 32	
U3 K (JP00205/2)	U5 K (JP09386/0)
U3 K spez. (JP09562/2)	U5 KS (JP09387/0)
U3 KS (JP00206/2)	U5 KS (JP09417/0)
U3 K spez. (JP44255)	U6 K E (JP00226/2)
U3 KS (JP09808/2)	U6 K D (JP00228/3)
U3 KS spez. (JP09563/2)	U6 K ES (JP00227/2)
U3 KS spez. (JP45195)	U6 K ES (JP09260/2)
	U6 K DS (JP00229/3)
	U6 K DS (JP09261/3)
Collecting and automatically lifting faecal-free waste water above the backflow level in buildings and sites	

REACTION TO FIRE	NPD
WATERTIGHTNESS	Pass
EFFECTIVENESS (LIFTING EFFECTIVENESS)	
- Pumping of solids	Pass
- Pipe connections	Pass
- Ventilation	NPD
- Minimum flow velocity	Pass
- Minimum free passage of the plant	Pass
- Minimum useful volume	NPD
MECHANICAL RESISTANCE	
- Load bearing capacity and structural stability of collection tank for use outside buildings	NPD
- Structural stability of collection tank for use inside buildings	NPD
NOISE LEVEL	≤ 70 dB(A)
DURABILITY	
- of structural stability	NPD
- of lifting effectiveness	Pass
- of mechanical resistance	NPD
DANGEROUS SUBSTANCES	NPD