

ULTRAVIOLET WATER TREATMENT & MICROFILTRATION SYSTEM

UV55 | FOR SMALL TO MEDIUM HOUSES.
55 litres per minute average demand.



UV75 | FOR MEDIUM TO LARGE HOUSES.
75 litres per minute average demand.



APPLICATIONS

- Designed to greatly improve the quality of your family's drinking water throughout your home
- Suitable for rain water, mains water and surface water treatment applications

BENEFITS OF THE SYSTEM

- Pentair Ultraviolet Micro Filtration System tested to remove 99.9999% of Escherichia Coli (e. Coli)*
- Pentair UV technology is a natural purification process that is friendly to the environment and free of chemicals.
- Proven Pentair owned and manufactured filtration housings, cartridges, and components.
- Multistage micro filtration & ultraviolet purification all-in-one unit.
- Reduces sediment, silt, sludge, dirt, rust, coarse and fine particles, chemicals including chlorine, bad taste, and odour.
- Turns your water into pure, safe, delicious drinking water throughout your home.
- Improves the quality of your water for washing, showering and cooking, can even protect your plumbing and appliances.
- Fabrics will last longer and look cleaner with filtered water.
- Commercial design for indoor or outdoor installation to withstand Australian climate conditions**
- Equipped with a UV lamp count-down timer and alarm to ensure the system is working at optimal performance, 100% of the time.

*SGS-CSTC Standards Technical Services GB/T 5750.12-2006 Standard examination methods for drinking water-Microbiological parameters
**Protect against freezing

REPLACEMENT CARTRIDGES FOR UV 55 MODELS

MODEL	FLOW RATE (l/pm)	STAGE	REPLACEMENT FILTER (CARTRIDGE MODEL TO ORDER)	PRODUCT CERTIFICATIONS
*UV5505	55	CARTRIDGE 1	5PP10BB	CSA B483.1 and NSF/ANSI STANDARD 53
		CARTRIDGE 2	PB3510	
UV5501	55	CARTRIDGE 1	DGD2501	NSF/ANSI STANDARD 42
		CARTRIDGE 2	DFXCBBB	
*UV5510	55	CARTRIDGE 1	NCP10BB	NSF/ANSI STANDARD 42
		CARTRIDGE 2	RFC10BB	

REPLACEMENT CARTRIDGES FOR UV 75 MODELS

*UV7505	75	CARTRIDGE 1	5PP20BB	CSA B483.1 and NSF/ANSI STANDARD 53
		CARTRIDGE 2	PB5520	
UV7501	75	CARTRIDGE 1	20DGD2501	NSF/ANSI STANDARD 42
		CARTRIDGE 2	DFXC20BB	
*UV7510	75	CARTRIDGE 1	NCP20BB	NSF/ANSI STANDARD 42
		CARTRIDGE 2	RFC20BB	

*Will be available in Q1 of 2023.

TECHNICAL DRAWINGS

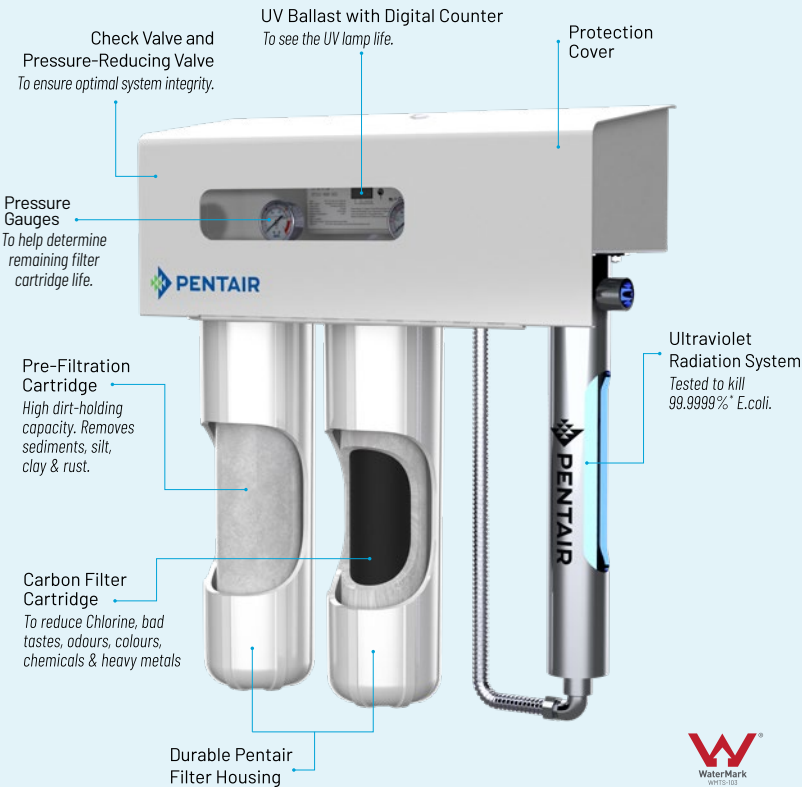
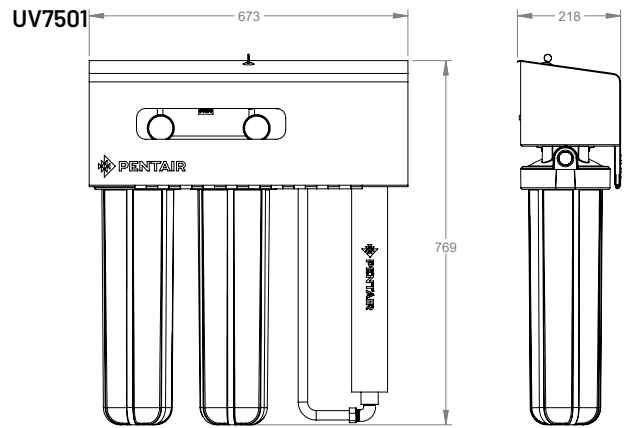
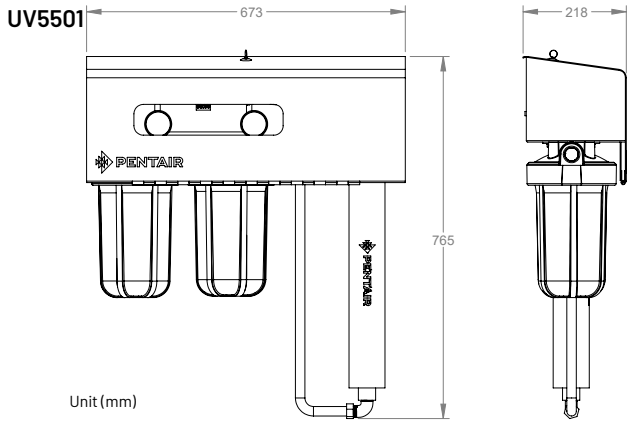

INLET SIZE

- 25mm (1" Bsp)

SYSTEM DIMENSIONS

- 721 W X 780 H X 218 D (Mm)

SYSTEM WEIGHT

Model	Dry Weight	Wet Weight (In Operation)
UV5505	22kg	32kg
UV7505	27kg	42kg

CONTAMINANT REDUCTION

- Kills 99.9999% Of E. Coli & waterborne bacteria.
- Chlorine taste and odour
- Cyst: NSF/ANSI Standard 53 certified to reduce cysts such as cryptosporidium and giardia by mechanical means (Models UV5505 and UV7505)

MICRON RATING

- UV5505/UV7505 : 0.5 Micron
- UV5501/UV7501 : 1 Micron
- UV5510/UV7510 : 10 Micron

APPROXIMATE FILTER CARTRIDGE LIFE

- Up To 12 months depending on mains water quality

SYSTEM CERTIFICATIONS AND STANDARDS

- Australian Watermark WWM-022617_03
- NSF/ANSI Standard 42, 53 (Components Only)
- CSA (Canadian Standards Association) Standard B483.1 for lead reduction. (Model PB55-20-SC-F80 and PB55-10-SC-F80)
- EMC: CISPR 15:2018
- Electrical Safety: AS/NZS 60335.1:2019, AS/NZS 60335.2.109:2017

MIN/MAX INLET WATER TEMPERATURE

- 4°C - 38°C

MIN/MAX INLET WATER PRESSURE

- 140 To 520 Kpa

MODEL	UV5501	UV7501	UV5505	UV7505	UV5510	UV7510
Flow Rate	55 lpm	75 lpm	55 lpm	75 lpm	55 lpm	75 lpm
Inlet Water Condition	Tap water / Surface Water / Rain Water					
Working Water Pressure	210 - 500 kPa (30 - 73 PSI)					
Min-Max Water Temperature	5 - 38°C					
Ambient Temperature	2 - 49°C					
Inlet Water Max Turbidity	≤ 5 NTU					
Inlet Water Max Dissolved Iron	≤ 0.3 ppm (0.3 mg/L)					
Inlet Water Max Hydrogen Sulfide	≤ 0.05ppm (0.05 mg/L)					
Inlet Water MAX Suspended Solids	≤ 10ppm (10 mg/L)					
Inlet Water Max Manganese	≤ 0.05ppm (0.05 mg/L)					
Inlet Water Max Hardness	≤ 1.84 mg/L					
Power Supply	AC 230VAC/50Hz					
Power	48W					